



6.9

2-way high-response proportional cartridge valve, pilot operated

Type 2WRCE...L1X

NG 25 to 100
Max. pressure 420 bar
Nominal flow 8000 L/min

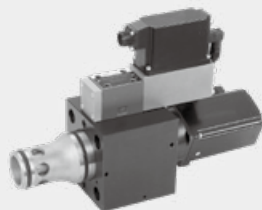

Contents

Function and configuration	02
Symbols	03
Ordering code	04
Technical data	05
Electrical connections	06
Characteristic curves	07-08
Unit dimensions	09-17
Installation dimensions	18

Features

- Pilot operated 2-way high-response valve in block installation design
- Suitable for closed-loop controlling of position, pressure, force and velocity
- Pilot control valve (pilot):
Directly actuated controlled directional valve, with control spool and sleeve in servo quality
- Main stage: closed-loop position controlled
- Integrated open and closed-loop control electronics (OBE)
- Typical applications:
 - Plastic injection machines
 - Die-casting machines
 - Ceramics machines

Function and configuration

Valves of type 2WRCE...-L1X/P... are 2-stage high-response valves. They control the quantity and direction of a flow and are mainly used in control loops.

Set-up:

They consist of the following assemblies:

- The pilot control valve (1) as 1-stage proportional valve (pilot), with a solenoid as electro-mechanical converters and a piston that is connected to the integrated pilot electronics via electrical feedback (6.2).
- The second stage (2) for flow control.
- An inductive position transducer (3) the core (4) of which is attached to the piston (5) of the second stage.
- Integrated LVDT electronics (6.1).

Type 2WRCE40...-L1X/P

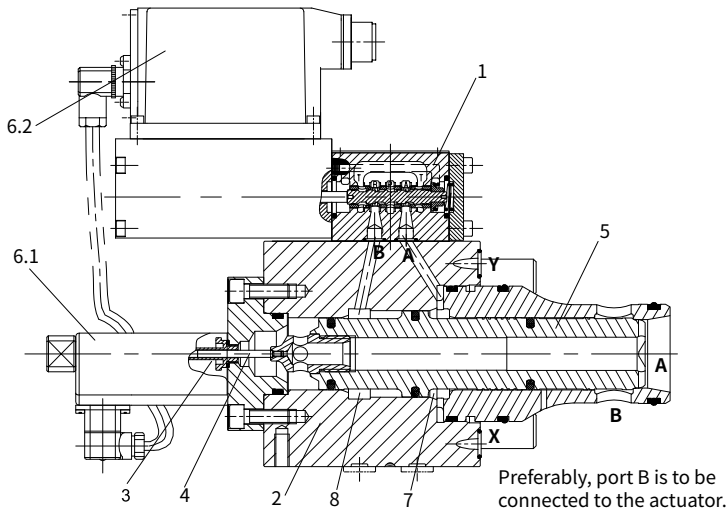

Function

The integrated electronics (OBE) compares command and actual values and the solenoids of the pilot control valve are actuated with a proportional current according to the control deviation.

The pilot control valve takes a proportionally controlled position and controls the flow in and out of the control chambers A (7) and B (8) that actuate the main spool (5) through the closed valve control loop up to 0 control deviation.

This means that the stroke of the main spool is regulated proportionally to the command value. It must be noted that the flow also depends on the valve pressure drop.

Symbols

2WRCE...L1X/PL...

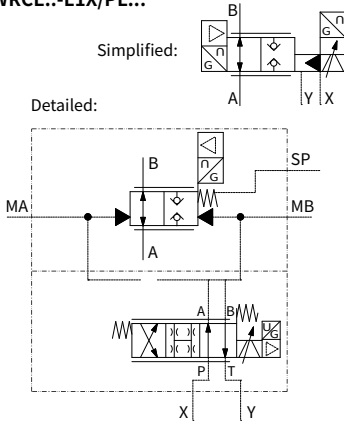

2WRCE...L1X/PK...

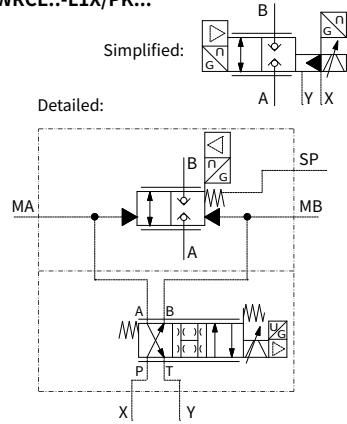

2WRCE...L1X/PWL...

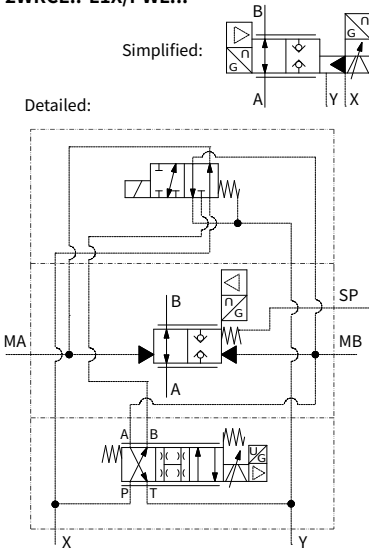

2WRCE...L1X/PWK...

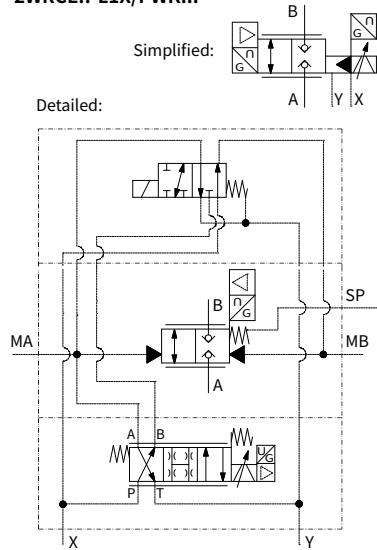

Ordering code

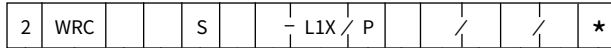

Two-way directional valve = 2

High-response proportional cartridge valve = WRC

With integrated electronics (OBE) = E

Size 25 = 25 Size 63 = 63
 Size 32 = 32 Size 80 = 80
 Size 40 = 40 Size 100 = 100
 Size 50 = 50

Seat piston = S

Rated flow in L/min at 5 bar valve pressure drop			
Size	Type ...S...L (linear)	Type ...S...R (linear with progressive fine control range)	
25	500 =500	-	
32	800 =800	600	=600
40	1200 =1K2	850	=850
50	2000 =2K0	1400	=1K4
63	3600 =3K6	3200	=3K2
80	4500 =4K5	3900	=3K9
100	8000 =8K0	6800	=6K8

Characteristic curve form

Linear = L
 Linear with progressive fine control range = R

Series L10 to L19 = L1X

(L10 to L19: Unchanged installation and connection dimensions)

The pilot valve is a proportional solenoid driven proportional servo valve = P

Sandwich plate shut-off valve:

Without shut-off valve, de-energized pilot control valve actively "closes" WRCE with applied pilot pressure =K

Without shut-off valve, de-energized pilot control valve actively "opens" WRCE with applied pilot pressure =L

With shut-off valve, de-energized shut-off valve actively "closes" WRCE with applied pilot pressure =WK

With shut-off valve, de-energized shut-off valve actively "opens" WRCE with applied pilot pressure =WL

Spool position monitoring:

Safety valve without position switch = No code
 With safety valve and position switch = E

Electrical interface:

Command value 0~10V (only with integrated electronics (OBE) "E") = A1
 Command value 4~20mA (only with integrated electronics (OBE) "E") = F1

Seal material: FKM seals = V NBR seals = No code

Enable signal control: Without band enable =No code Band enable =Q

Further details in the plain text

Technical data

General			25	32	40	50	63	80	100
Size			25	32	40	50	63	80	100
Weight	Without shut-off valve .../...K or .../...L	kg	8.5	11.2	17.3	24.6	47	74	110
	With shut-off valve .../...WK or .../...WL...	kg	9.8	12.5	18.6	25.9	60	87	123
Size of the pilot control valve (pilot)		NG	6						
Installation position			Any, preferably horizontal						
Storage temperature range		°C	-20 to +80						
Ambient temperature range		°C	-20 to +50						
Sine test according to EN 60068-2-6			10 to 2000Hz/ max. of 10g/ 10 cycles/ 3 axes						
Noise test according to EN 60068-2-64	Size (NG) 25-40		20 to 2000Hz/ 10gRMS /30 g peak /30min /3 axes						
	Size (NG) 50-100		20 to 2000Hz/ 10gRMS /30 g peak /24h /3 axes						
Transport shock according to EN 60068-2-27			15g/ 11ms/ 3 axes						

Hydraulic (measured with HLP32, $\vartheta_{oil}=40^{\circ}\text{C} \pm 5^{\circ}\text{C}$)									
Maximum operating pressures	Main stage ports A, B	bar	420						
	Pilot control valve port X	bar	315						
	Pilot control valve port Y	bar	35						
Rated flow at $\Delta p = 5$ bar	Design ...S...L (linear)	L/min	500	800	1200	2000	3600	4500	8000
	Design ...S...R (linear with progressive fine control range)		-	600	850	1400	3200	3900	6800
Nominal flow of pilot valve at $\Delta p=70$ bar		L/min	12	12	40	40	100	100	100
Leakage of pilot valve at P = 100 bar		L/min	0.3	0.3	0.7	0.7	1	1	1
Hydraulic fluid			Mineral oil (HL, HLP) to DIN 51524						
Hydraulic fluid temperature range		°C	-20 to +80; preferably +40 to +50						
Viscosity range		mm ² /s	20 to 380; preferably 30 to 45						
Max. permissible degree of contamination of the pressure fluid is to ISO 4006 (c).	Pilot control valve		Class 18/16/13						
	Main valve		Class 20/18/15						
Hysteresis		%	≤ 0.2						
Range of inversion		%	≤ 0.1						
Response sensitivity		%	≤ 0.1						
Response time 0 ~ 100% step signal		ms	25	28	30	30	35	40	50

Electric			Direct voltage						
Voltage type			Analog						
Type of signal			Analog						
Opening point calibration		%	≤ 1						
Zero shift upon change of:	- Hydraulic fluid temperature	%/10 K	≤ 0.3						
	- Pilot pressure in X	%/100 bar	≤ 0.7						
	- Return flow pressure in Y	%/bar	≤ 0.3						
Protection class of the valve according to EN60529			IP65 with mating connector mounted and locked						

Nominal command value range for 2WRCE:

0 to +10 V $\underline{\Delta}$ 0 to 100%

In the command value range of 0 to 0.5 V, the actual value remains constant at 0.5 V.

In case of a slow command value modification from 0.5 V to +10 V, the actual value follows the command value within ± 0.15 V.

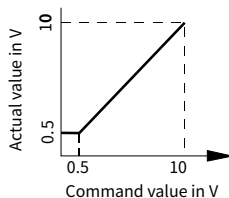

Electrical connections, plug-in connectors

Installation recommendations

An insufficient pilot oil supply (e.g. due to long distances and/or small diameters) can negatively influence the dynamics of the valve.

To avoid this, an accumulator can be connected to port SX at the valve body. A short-term undersupply with pilot oil can be compensated via this accumulator.

Sizing data: see operation manual.

Pinout: 2)

Pin assignment 6+PE

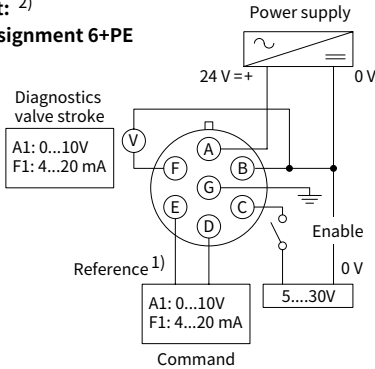

Notes:

1) Cannot be connected to 0V of the power supply voltage.

2) This model of product can provide dedicated debugging cables, and can be ordered separately if needed.

Seven-pin plug

Pin	Interface type (voltage type)	Interface type (current type)	Remarks
A	24VDC	24VDC	Power supply
B	0V	0V	
C	0V (without enable)/ 24VDC (with enable)	0V (without enable)/ 24VDC (with enable)	Enable signal specification: 5-30V to activate, approximately 0V to deactivate, with reference potential at pin B
D	0-10V	4-20mA	Command input
E	Command voltage reference potential	Command voltage reference potential	
F	0.2-+10V	4.3-20mA	Main valve spool feedback output, reference potential at pin B
PE	Chassis ground	Chassis ground	

Safety valve wiring diagram 3)

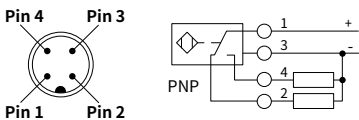

Note:

3) Refer to this wiring for safety valves with position detection.

Pin	Function
Pin1	+24V
Pin2	Normal close (low impedance - high impedance)
Pin3	0V
Pin4	Normal open (high impedance - low impedance)

Characteristic curves (measured with HLP46, $\theta_{oil}=50^{\circ}\text{C}$, $\Delta P=5\text{bar}$)

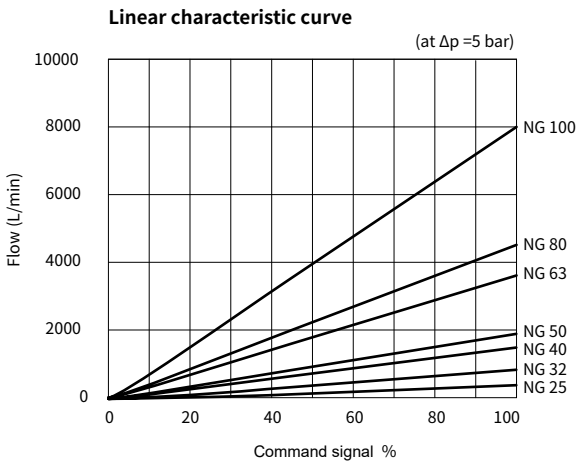
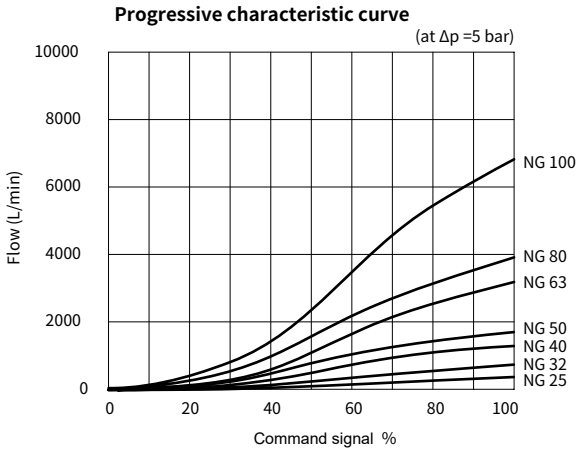

Opening point
factory set to 3%

Opening point factory set to 3%.

Flow at different Δp : $Q_{\text{actual}} = Q_{\text{nominal}} \cdot \sqrt{\frac{\Delta p_{\text{actual}}}{\Delta p_{\text{nominal}}}}$

06

Characteristic curves (measured with HLP46, $\vartheta_{oil}=50^{\circ}\text{C}$, $\Delta P=5\text{bar}$)

Bode diagram
(at nominal hydraulic conditions)

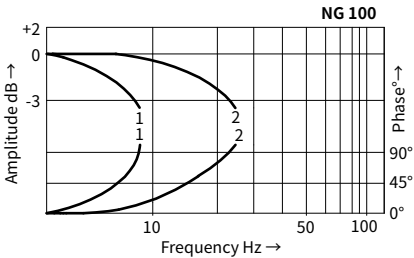
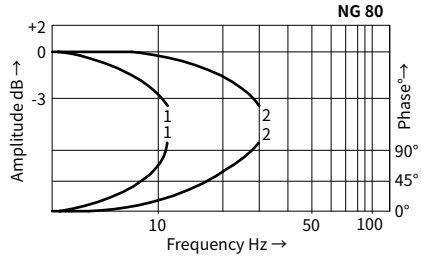
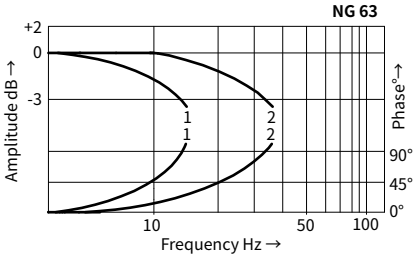
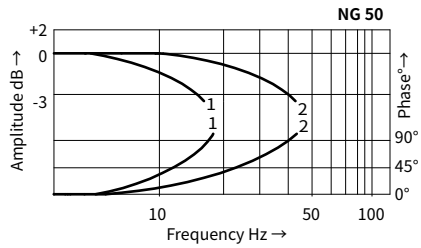
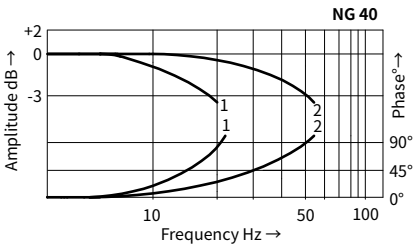
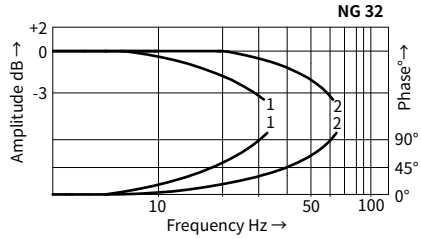
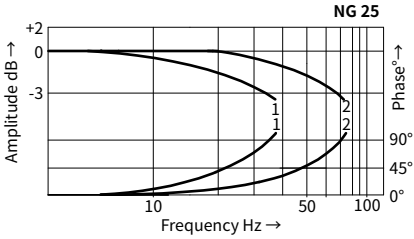

1 = Command value: 10% ↔ 90%
2 = Command value: 50% ± 5%

06

Unit dimensions

(nominal dimensions in mm)

NG 25

- 2WRCE...PK..., without safety valve

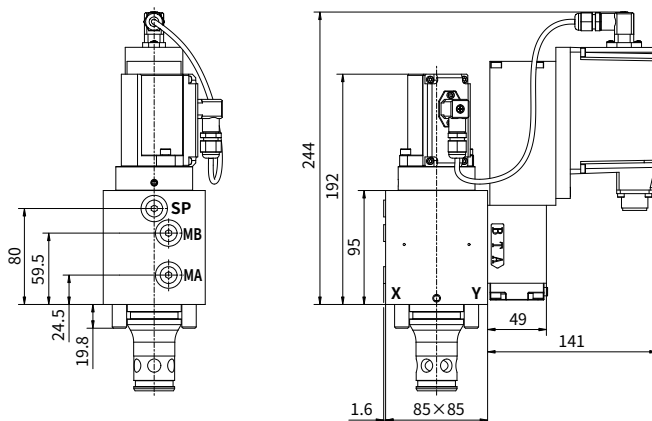

- 2WRCE...PWKE..., with safety valve and position switch

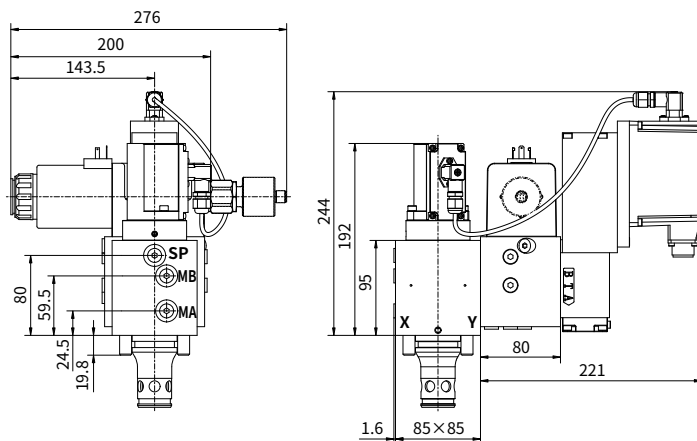

Suction port: SP = G1/4"
 Pressure measurement ports:
 MA and MB = G1/4"

Size	Fastening bolts DIN912 12.9	Tightening torque
25	4 - M12×100	125Nm

Unit dimensions

(nominal dimensions in mm)

NG 32

· 2WRCE...PK..., without safety valve

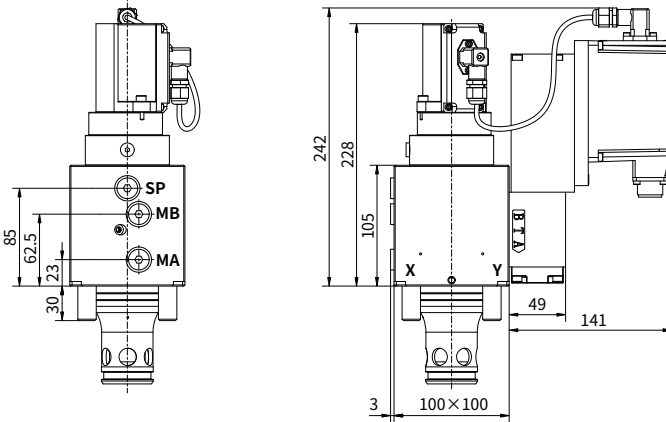

· 2WRCE...PWKE..., with safety valve and position switch

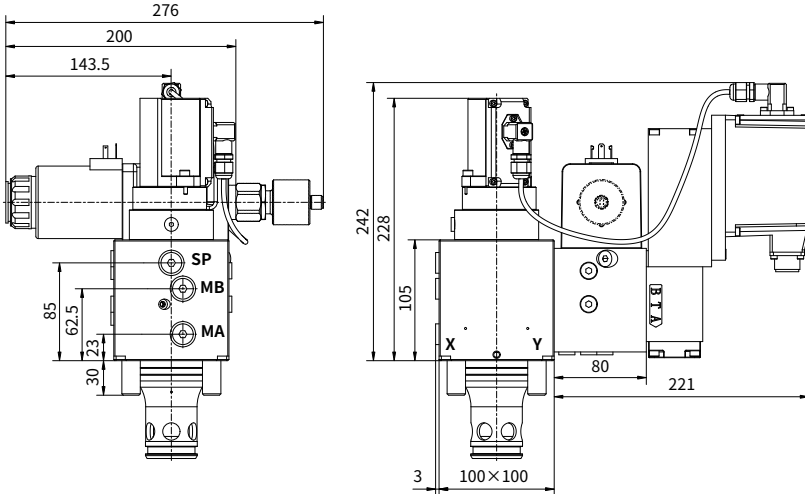

Suction port: SP = G1/4"
 Pressure measurement ports:
 MA and MB = G1/4"

Size	Fastening bolts DIN912 12.9	Tightening torque
32	4 - M16×60	300Nm

Unit dimensions

(nominal dimensions in mm)

NG 40

- 2WRCE...PK..., without safety valve

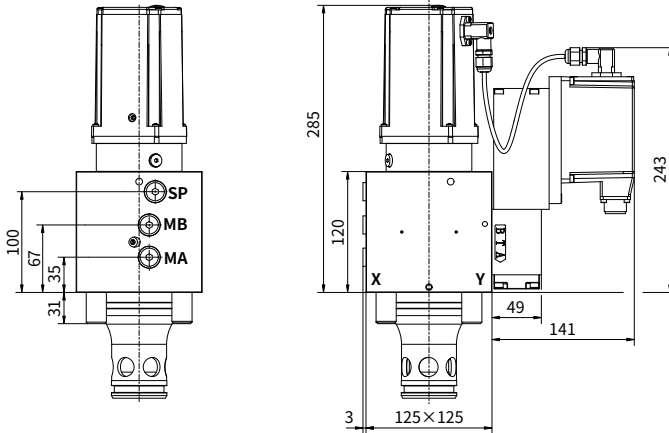

- 2WRCE...PWKE..., with safety valve and position switch

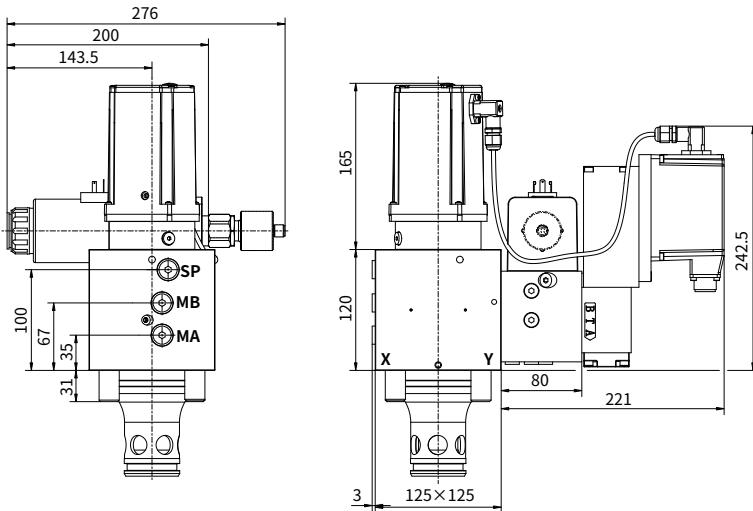

Suction port: SP = G1/4"
 Pressure measurement ports:
 MA and MB = G1/4"

Size	Fastening bolts DIN912 12.9	Tightening torque
40	4 - M20×70	600Nm

Unit dimensions

(nominal dimensions in mm)

NG 50

• 2WRCE...PK..., without safety valve

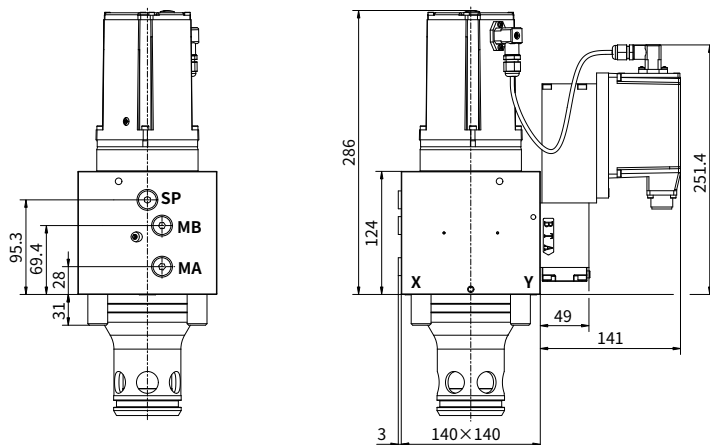

• 2WRCE...PWKE..., with safety valve and position switch

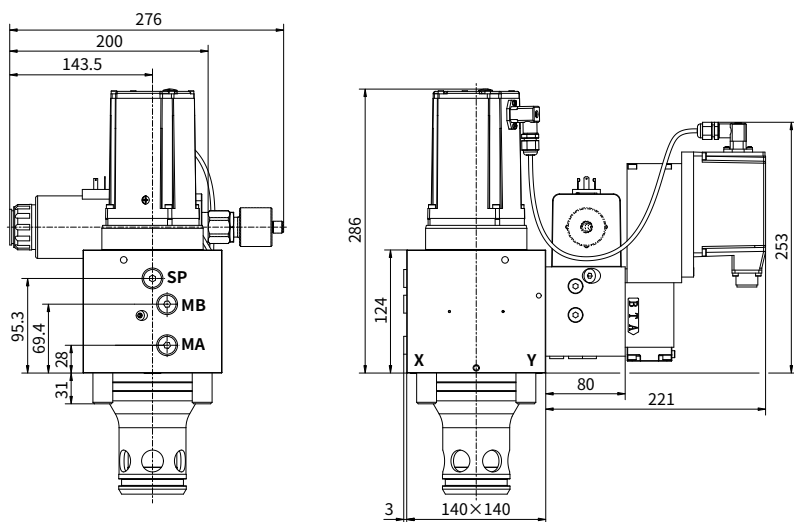

Suction port: SP = G1/4"
 Pressure measurement ports:
 MA and MB = G1/4"

Size	Fastening bolts DIN912 12.9	Tightening torque
50	4 - M20×80	600Nm

Unit dimensions

(nominal dimensions in mm)

NG 63

- 2WRCE...PK..., without safety valve

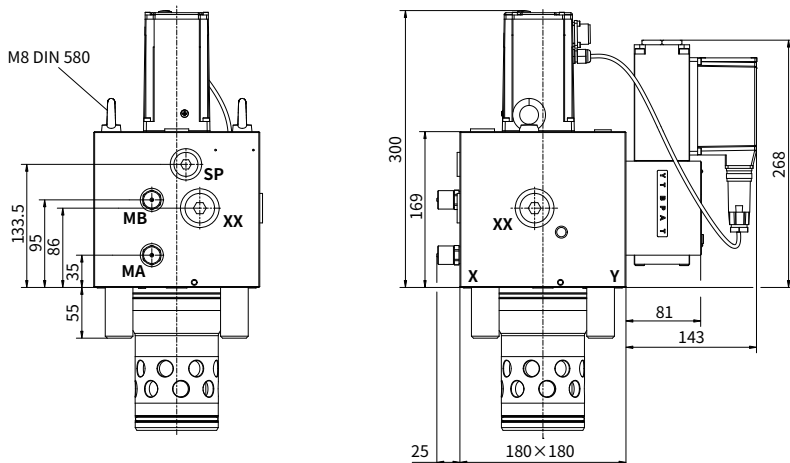

- 2WRCE...PWKE..., with safety valve and position switch

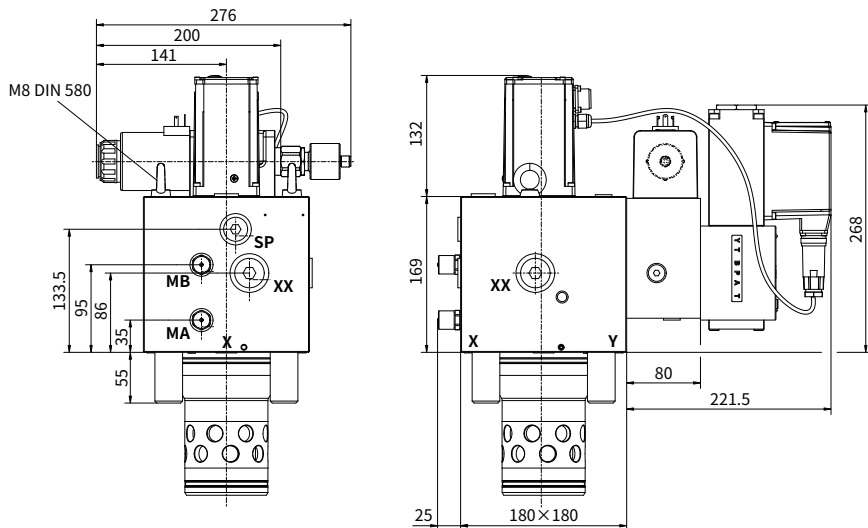

Suction port: SP = G1/2"
 Accumulator port: XX = G3/4
 Pressure measurement ports:
 MA and MB = G1/4"; MY = G1/4"

Size	Fastening bolts DIN912 12.9	Tightening torque
63	4 - M30 × 160	1775Nm

Unit dimensions

(nominal dimensions in mm)

NG 80

- 2WRCE...PK...,
without safety valve

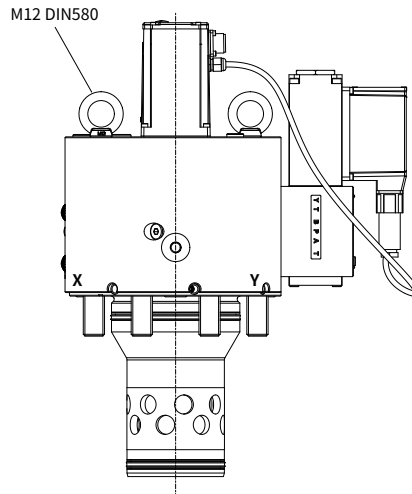
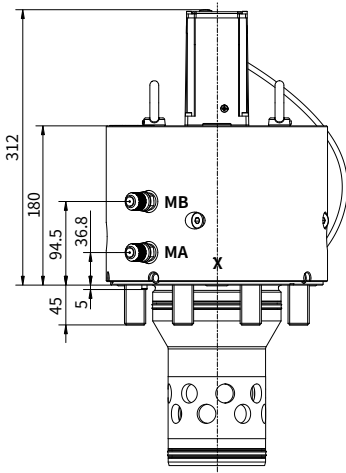
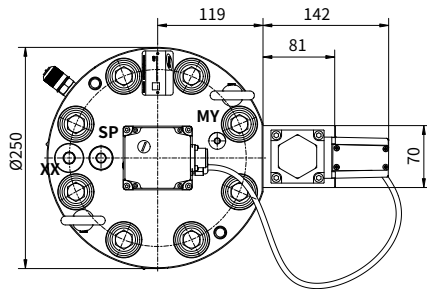

Suction port: SP = G1/2"
 Accumulator port: XX = G3/4
 Pressure measurement ports:
 MA and MB = G1/4"; MY = G1/4"

Size	Fastening bolts DIN912 12.9	Tightening torque
80	8 - M24 × 160	890Nm

Unit dimensions

(nominal dimensions in mm)

NG 80

- 2WRCE...PWKE...,
with safety valve and position switch

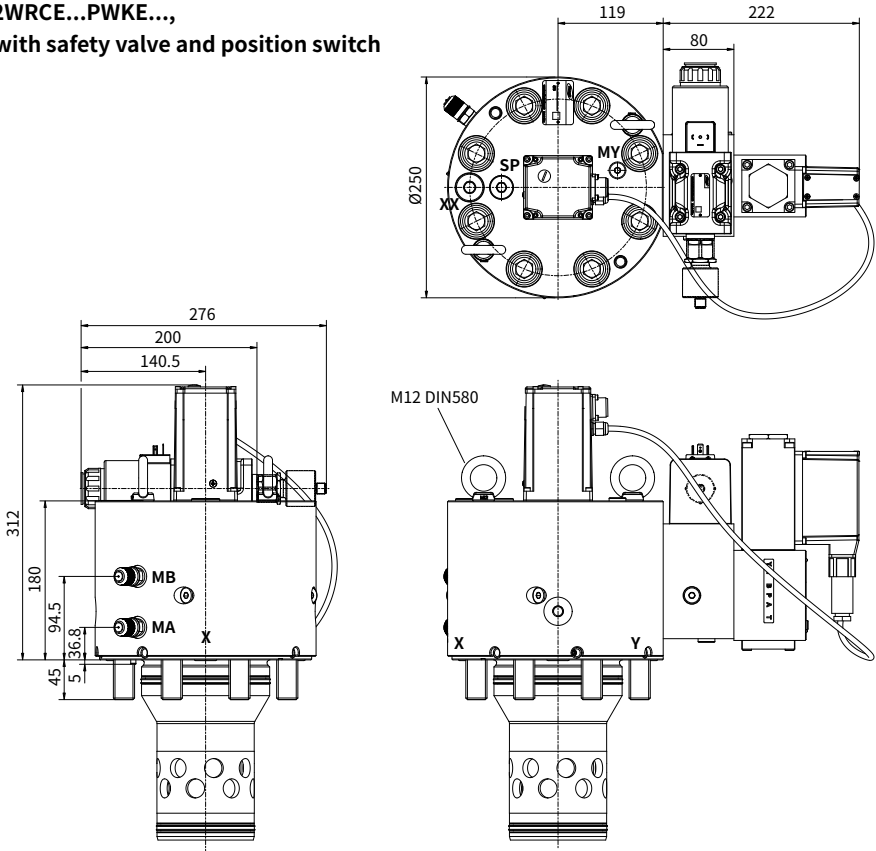

Suction port: SP = G1/2"
 Accumulator port: XX = G3/4
 Pressure measurement ports:
 MA and MB = G1/4"; MY = G1/4"

Size	Fastening bolts DIN912 12.9	Tightening torque
80	8 - M24×160	890Nm

Unit dimensions

(nominal dimensions in mm)

NG 100

- 2WRCE...PK...,
without safety valve

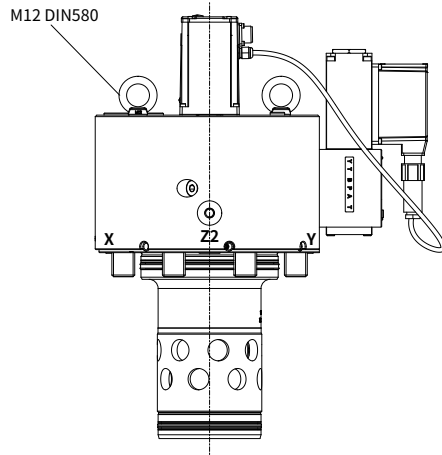
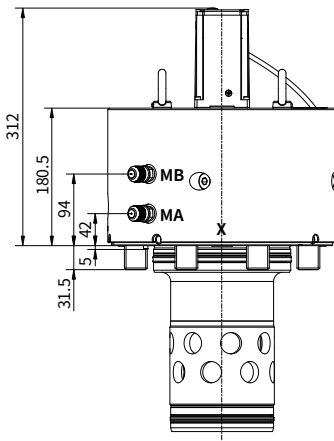
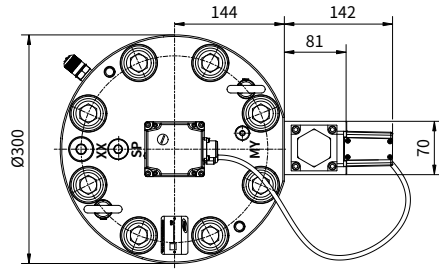

Suction port: SP = G1/2"
 Accumulator port: XX = G3/4
 Pressure measurement ports:
 MA and MB = G1/4"; MY = G1/4"

Size	Fastening bolts DIN912 12.9	Tightening torque
100	8 - M30 × 150	1775Nm

Unit dimensions

(nominal dimensions in mm)

NG 100

- 2WRCE...PWKE...,
with safety valve and position switch

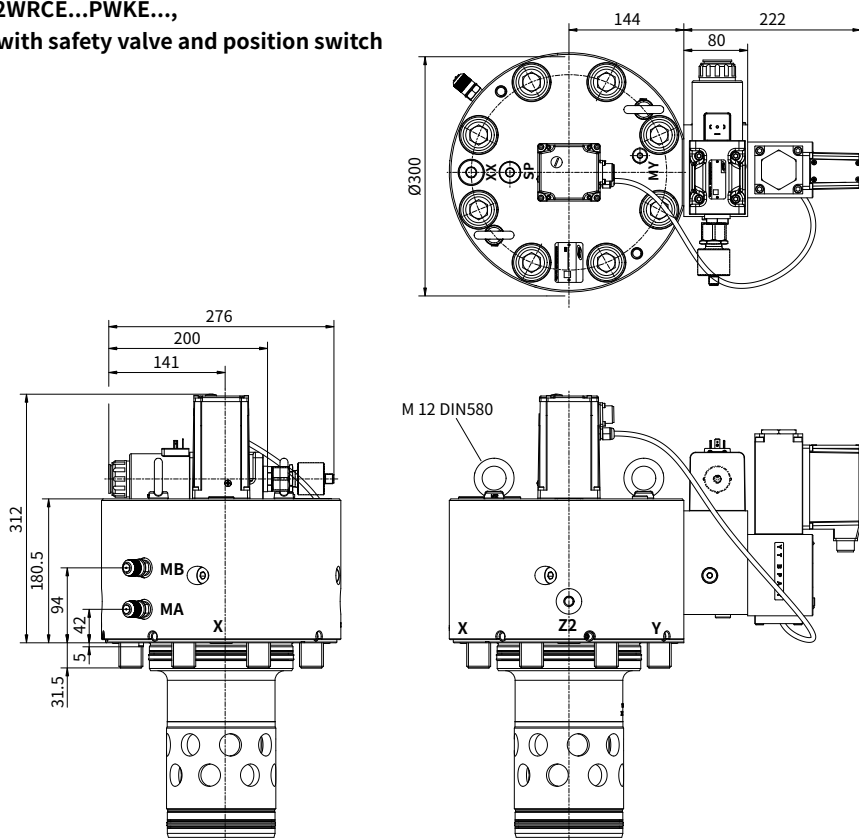

Suction port: SP = G1/2"
 Accumulator port: XX = G3/4
 Pressure measurement ports:
 MA and MB = G1/4"; MY = G1/4"

Size	Fastening bolts DIN912 12.9	Tightening torque
100	8 - M30×150	1775Nm

Installation dimensions according to DIN ISO 7368

(dimensions in mm)

NG 25-63:

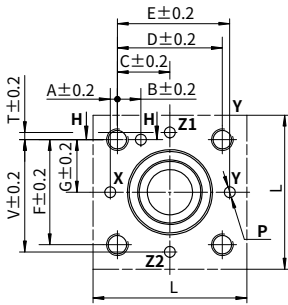

NG 80, 100:

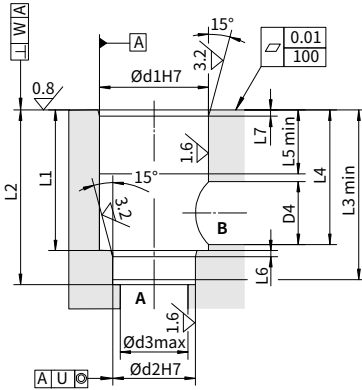
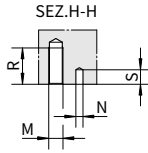
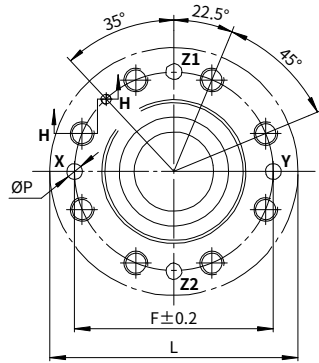

Size	25	32	40	50	63	80	100
A	4	6	7.5	8	12.5	-	-
B	13	18	19.5	20	24.5	-	-
C	29	35	42.5	50	62.5	-	-
D	58	70	85	100	125	-	-
E	62	76	92.5	108	137.5	-	-
F	58	70	85	100	125	200	245
G	29	35	42.5	50	62.5	-	-
L _{min}	85	102	125	140	180	250	300
M	M12	M16	M20	M20	M30	M24	M30
ØN	6	6	6	8	8	10	10
ØP _{max}	6	8	10	10	12	16	20
R	30	38	46	46	66	50	66
S _{max}	8	8	8	8	8	8	10
T	4	6	7.5	8	12.5	-	-
V	62	76	92.5	108	137.5	-	-
Ød1	45	60	75	90	120	145	180
Ød2	34	45	55	68	90	110	135
Ød3 _{max}	25	32	40	50	63	80	100
Ød4 _{max}	27	38.5	54.5	62.5	87	100	120
L1	58 ^{+0.1} ₀	70 ^{+0.1} ₀	87 ^{+0.1} ₀	100 ^{+0.1} ₀	130 ^{+0.1} ₀	175 ^{+0.2} ₀	210 ^{+0.2} ₀
L2	72 ^{+0.1} ₀	85 ^{+0.1} ₀	105 ^{+0.1} ₀	122 ^{+0.1} ₀	155 ^{+0.1} ₀	205 ^{+0.2} ₀	245 ^{+0.2} ₀
L3	70	83	102	117	150	200	239
L4	57	68.5	84.5	97.5	127	170.5	205.5
L5	30	30	30	35	40	40	50
L6	2.5	2.5	3	3	4	5	5
L7	2.5	2.5	3	3	4	5	5
U	0.03	0.03	0.05	0.05	0.05	0.05	0.05
W	0.05	0.1	0.1	0.1	0.2	0.2	0.2